

# ACCENTO PROFESSIONAL 36"

36" ALL GAS PROFESSIONAL RANGE



CODE ID



**F4PGR366S1**



Heavy Duty Grates



Continuous Grate Surface



Dual Crescendo Burner



Dual Convection



Cool Touch Door



Multi-level cooking



Digital minute minder

## COLOR KIT

	STAINLESS STEEL
	MATTE BLACK RAL 9004
	MATTE WHITE RAL 9016
	GLOSSY RED RAL 3003

## OPTIONAL ACCESSORIES

ACDKIT36 ...	Colour kit
FMWOK	Wok ring
FMSIM	Simmer plate
F6BG30BCI	Island trim
F6BG30STD	Standard trim
F6BG30HBT	High back trim
FMGRID30	Griddle
FMTRP30	Telescopic rack

## COOKING SURFACE

3 Heavy Duty, continuous cast iron grates  
One piece, matte finish porcelain burner bowl  
3 Dual-Flame Crescendo Burners  
3 X 18,000 BTU max (NG)  
3 Rapid Burners  
3 X 15,000 BTU max (NG)  
Natural Gas (LP convertible)

## OVEN

Dual Convection  
Black Porcelain enamel interior  
Cool to touch door  
Extra-large baking cavity and viewing area  
3 Halogen lights for flawless visibility  
Gross capacity 4.4 cu. ft.  
2 chromed racks  
Enameled Grill set

## OVEN FUNCTIONS

Bake  
Broil  
Convection  
Pizza cooking  
Dehydrate  
Timer

# ACCENTO

36" ALL GAS PROFESSIONAL RANGE

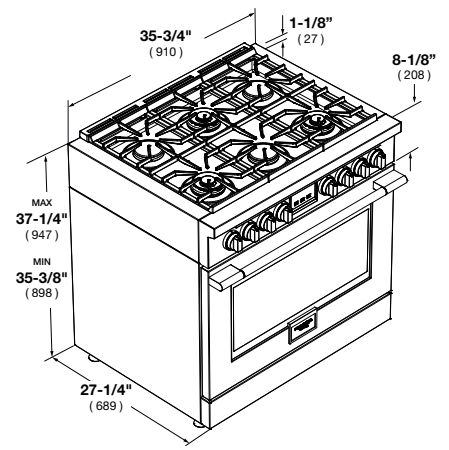

CODE ID	F4PGR366S1 - 36" FULL GAS PROFESSIONAL RANGE		
Series and Finish	400 Series - Professional Design - Stainless Steel		
<b>CONTROL PANEL</b>			
Control Type	Valve		
Clock Display	•		
<b>COOKTOP</b>			
Cooking Surface	Matte Black Enameled		
Type	GAS (NG or LP)		
<b>GAS COOKTOP FEATURES</b>			
	Electric Flame and Re-ignition	Top Mount Injectors	Dual Crown Brass Burner
	Flame-out sensing	L.P. Conversion Kit	Pressure Regulator
Heavy Duty Cast Iron Grates	3		
Cooking Zones	6		
Burners types	Dual Flame/Rapid Burners		
Power Front L+R (Max/Min) G20 - 5" (NG)	18000 (BTU/h) - 5300W / 950 (BTU/h) - 275W		
Power Rear L+R (Max/Min) G20 - 5" (NG)	15000 (BTU/h) - 4400W / 2200 (BTU/h) - 645W		
Power Front Middle (Max/Min) G20 - 5" (NG)	15000 (BTU/h) - 4400W / 2200 (BTU/h) - 645W		
Power Rear Middle (Max/Min) G20 - 5" (NG)	18000 (BTU/h) - 5300W / 950 (BTU/h) - 275W		
Power Front L+R (Max/Min) G31 - 10" (LP)	15000 (BTU/h) - 4400W / 950 (BTU/h) - 275W		
Power Rear L+R (Max/Min) G31 - 10" (LP)	12000 (BTU/h) - 3500W / 2200 (BTU/h) - 645W		
Power Front Middle (Max/Min) G31 - 10" (LP)	12000 (BTU/h) - 3500W / 2200 (BTU/h) - 645W		
Power Rear Middle (Max/Min) G31 - 10" (LP)	15000 (BTU/h) - 4400W / 950 (BTU/h) - 275W		
<b>OVEN</b>			
Type	Multifunction 2 Fans (True Euro Conv.)		
Temperature Regulation	Thermostat		
Injection Oven	T-Zero		
<b>OVEN FUNCTIONS</b>			
	Pizza ( Lower Convection )	Down Bake	Broil
<b>GAS OVEN FEATURES</b>			
	Electronic Flame Ignition	Gas safety devices	L.P. Conversion Kit
	Flame-out Sensing		
<b>OVEN DOOR(S)</b>			
Oven Glass Window	Deep Embossed Window		
Door Cooling System	4 Pane Heat Resistant Glasses		
Door Hinges	Heavy Duty Steady Tilt		
Handle Style	Stainless Steel Tube d30mm, Metal terminals		
<b>OVEN CAVITY</b>			
Gross Capacity (cbft)	4.4		
Cavity Enamel Colour	Black		
Rack Positions	6		
Oven Lights	3x20W Halogen		
<b>BOTTOM BURNER</b>			
Power (Max) G20 - 5"	18000 (BTU/h) - 5300W		
Power (Max) G31 - 10"	16000 (BTU/h) - 4700W		
<b>GRILL BURNER</b>			
Power (Max) NG	14000 (BTU/h) - 4102W		
Power (Max) LP	13000 (BTU/h) - 3800W		
<b>OVEN ACCESSORIES</b>			
Chromed Racks	2 racks without frontal bend		
Enameled Grill set (basin + anti splash)	1		
Telescopic Chromed Rack	only as optional ACCESSORY		
<b>DIMENSIONS/WEIGHT</b>			
Overall dim - Width	29 - 3/4"	(758 mm)	
Overall dim - Height (min - max)	39"	(993 mm)	
Overall dim - Depth	29 - 3/4"	(756 mm)	
<b>POWER / RATINGS (120 V, 60 HZ)</b>			
KW/Amps rating rating at 120V, 60Hz	200W - 1.7A		
Cable + Plug	Nema 5-15P		
<b>INSTRUCTIONS FOR USE</b>			
Use & Care Manual / Installation Manual	English / French / Spanish		