



PROFESSIONAL QUALITY COOKING EQUIPMENT

USE AND CARE MANUAL FOR
HERITAGE GAS RANGES
TITAN GAS RANGES

MODEL NUMBERS: ARR-244, ARR-304, ARR-364GD, ARR-366, ARR-364GR, ARR-486GD, ARR-484X2GR,
ARR-484GDGR, ARR-4842GD, ARR-486GR, ARR-606GDGR, ARR-6062GD, ARR-606X2GR,
ARR-244IS, ARR-304IS, ARR-366IS



DESIGN



CLASS



FUNCTION

RETAIN THIS MANUAL FOR FUTURE REFERENCE



FOR YOUR SAFETY!
Do not store or use gasoline or other flammable vapors or liquids in the vicinity of this or any other appliance.

WARNING!
Improper installation, adjustment, alteration, service or maintenance can cause property damage, injury or death and will void warranty. Read the installation, operating and maintenance instructions thoroughly before installing or servicing this equipment.

IMPORTANT SERVICE NOTICE!
Using any part other than genuine American Range factory supplied parts relieves the manufacturer of all liability.
American Range reserves the right to change specifications and product design without notice. Such revisions do not entitle the buyer to corresponding changes, improvements, additions or replacements for the previously purchased equipment.

Instruction to be followed in the event the user smells gas should be posted in a prominent location. This information should be obtained by consulting the local gas supplier.

RETAIN THIS MANUAL FOR FUTURE REFERENCE.

Model Number: _____

Serial Number: _____

Purchase Date: _____

Installed By: _____ Install Date: _____

Gas Type: _____

Electrical Information: _____



PROFESSIONAL QUALITY COOKING EQUIPMENT

To Our Most Valued Customer:

Congratulations on your purchase of an American Range product. We hope you will enjoy the design, manufactured quality, innovative features and cooking performance of this product – it represents our continuing dedication to satisfying the most demanding needs of customers like you.

Please read this manual and become familiar with important safety information about how to install and set-up the unit, basic operating instructions, and how to maintain that just-like-brand-new appearance and performance - over years of day-to-day and special holiday use.

If you should encounter any sort of problem, turn to the section of the manual entitled, "Troubleshooting" – for a quick solution or guidance regarding the next step required to get back to tip-top condition.

Thank you for choosing an American Range product for your home. As you can expect, this appliance is designed for years of reliable service. If you have any questions or comments, please contact the dealer from whom you purchased the unit, or contact American Range Customer Service at www.americanrange.com or 818.897.0808.

Sincerely,

Shane Demirjian

President, American Range Corporation



Table of Contents

GENERAL 1-5
 General Information 1
 About This Manual 2
 Shipping Damage Claim Procedure 3
 Precautions 3-5

INSTALL 6-20
 Site Preparation 6
 Cabinet Preparation 6
 Electrical Connection 6
 Gas Connection 6
 Gas Regulator 7
 Gas Requirements 7
 Gas Connection/Flexible Connectors 7
 Rating Plate 7
 Additional Installation Instructions 8
 Installation Diagrams 9-16
 Typical Model Parts and Identification 17
 Model and Parts Identification Table 18
 Installation Checklist 19
 Performance Checklist 20
 Start-up Procedure 20

OPERATE 21-25
 Cook Top 21
 Burners 21
 Auto Re-ignition 21
 Cookware 22
 Suggested Burner Settings 22
 Ovens 23
 Broil 23
 Grill 24
 Griddle 25

MAINTAIN 26-29
 Care and Cleaning 26
 Cleaning Recommendations Chart 27
 Baking Chart 28
 Roasting Chart 29
 Broiling Chart 29

TROUBLESHOOT 30



WARNING

If the information in this manual is not followed exactly, a fire or explosion may result causing damage, personal injury or death.

- INSTALLATION AND SERVICE MUST BE PERFORMED BY A CERTIFIED / LICENSED INSTALLER, SERVICE AGENCY OR THE GAS SUPPLIER
- Do not store or use gasoline or other flammable vapors or liquids in the vicinity of this or any other appliance.

- WHAT TO DO IF YOU SMELL GAS
 - Do not try to light any appliance.
 - Do not touch any electrical switch, do not use any phone in your building.
 - Immediately call your gas company. Follow the gas supplier instructions.
 - If you cannot reach your gas supplier, call the Fire Department.

WARRANTY REQUIREMENT

For reliable operation and for your own safety, this professional cooking equipment must be installed by a certified/licensed contractor.

Failure to comply will void any written or implied warranty.

Should the equipment require service during the standard warranty period, the receipt proving certified installation must be made available to American Range for verification.

If installation was not performed by a certified/licensed contractor be prepared to submit a major credit card for payment for proper installation.

- Please observe all local and national codes and ordinances.
- Do not remove any permanent warning labels or plates from this product.
- Please ensure that this product is electrically grounded.
- Consumers should retain these instructions for local inspectors and for future use.

- The included Anti-Tip Device must be installed prior to operation

ABOUT THIS MANUAL

The Use and Care Manual is divided into several sections:

The Safety Section informs you about significant safety precautions when installing and operating your new appliance. This is a must read section of the manual.

Quick Start and Installation Section describes how to unpack the unit, what to save and what to discard, installation dimensions, gas and electrical connections and how to identify the primary parts of the product so you can better understand what's going on "under the hood".

How to Use Your Product and How to Use the Oven (where applicable) Sections show you how to light the burners, set the range for broil or bake and how to use convection to speed cooking times and improve the quality of your baked and roasted dishes.

The Care and Maintenance and Troubleshooting and Service Sections discuss how to keep your product in good operating condition, how to identify what might be going wrong with the unit, and how to communicate your observations with authorized field service technicians.

Before using your appliance, please read this manual paying special attention to the important safety instructions located in the next several pages.



This is the SAFETY ALERT SYMBOL. This symbol alerts you to hazards which will result in severe injury or death.



DANGER

Hazards or unsafe practices which will result in severe personal injury or death.



WARNING

Hazards or unsafe practices which may result in severe personal injury or death.



CAUTION

Hazards or unsafe practices which may result in minor personal injury or property damage.

PRECAUTIONS

SHIPPING DAMAGE CLAIM PROCEDURE

The equipment is crafted and inspected carefully by skilled personnel before leaving the factory. The transportation company assumes full responsibility for the safe delivery upon acceptance of the equipment.

If you receive a damaged product, immediately contact your delivery company, your dealer, your builder or installer. Do not install or attempt to operate a damaged appliance.

1. Note any visible loss or damage on the freight bill or express delivery and have the note signed by the person making the delivery.
2. File claim for damages immediately regardless of the extent of damages.
3. For damage noticed after unpacking (concealed loss or damage), notify the transportation company immediately and file a "Concealed Damage" claim with them. This should be done within fifteen (15) days from the date that delivery is made to you. Retain the shipping container for inspection.

CAUTION

Check your local building codes for proper installation methods. In the absence of local codes, this appliance should be installed in accordance with the National Fuel Gas Code No. Z223.1 current issue, and the National Electrical Code ANSI/NFPA No. 70 current issue, or the CAN – B149 Installation Codes for Gas Burning Appliances, and C22.1 Canadian Electrical Code Part I. Verify the type of gas supplied to the location, being sure that the appliance is connected to the type of gas for which it is certified. Models come from the factory certified for use with Natural Gas (NG) or Liquid Propane (LP) gas. Your product gas type, shown on the rating label and the supplied gas type must be the same. Upon opening your product, the rating label can be located on the front panel if it is a range or oven. If it is a cook top it can be found on the side panel underneath the left burner.

If connecting this appliance to propane gas, make certain the propane gas tank is equipped with its own high-pressure regulator - in addition to the pressure regulator supplied with this product when applicable. The maximum propane gas pressure to this appliance must not exceed 14.0 inches of water column (34.9 millibar) from the propane gas tank to the pressure regulator. Your appliance must be installed by a qualified gas installation technician. Have the technician show you the exact location of the gas shut-off valve on the incoming gas line so you know how to turn off the gas if necessary.

CAUTION

For personal safety, this appliance must be connected to a properly grounded and polarized electrical power supply. If only a two-prong outlet is available, it is the customer's responsibility to have a licensed technician replace it with a dedicated, grounded, three-prong electrical outlet. The gas surface burner re-ignition system depends on a low resistance electrical ground connection for reliable operation.

- Do not cut or remove the third (ground) prong from the power cord
- Do not use an adapter plug
- Do not use an extension cord
- Do not use a power cord that is frayed or damaged
- Do not plug the appliance into an electrical outlet with a Ground Fault Circuit Interrupter (GFCI)

**DANGER**

To avoid the possibility of explosion or fire, do not store or use combustible, flammable or explosive liquids (such as gasoline) or vapors inside or in the vicinity of this or any other appliance. Keep items that could explode, such as aerosol cans, away from the product. Do not store explosive or flammable materials in nearby cabinets or areas. When operating the oven or broiler, do not touch the surfaces of the ceramic tile broiler, the rack or rack supports, the walls of the oven or the inside surfaces of the oven door - interior surfaces become hot enough to cause burns. The heat deflector, which deflects heat away from the control panel, and the oven door sides will also be hot during use.

**DANGER**

Do not store items of interest to children above or near the appliance. Children, as well as adults, should never be allowed to sit, stand or climb on any part of the appliance. Serious personal injury may occur.

**WARNING**

Always disconnect the electrical plug from the wall outlet before servicing the unit. It is recommended that a dedicated electrical circuit be used for this appliance. Always turn gas shut-off valve to OFF position before servicing unit.

**WARNING****POWER FAILURE WARNING**

Due to safety considerations and the possibility of personal injury, do not attempt to light or operate range burners, grills, griddles, the oven or broiler during a power failure. Safety systems which detect the presence of an ignition source and operate the gas safety valve do not function during a power failure. Be sure all gas valve knobs are turned to and remain in the OFF position during a power failure.

IMPORTANT SAFETY NOTICE AND WARNING

The California Safe Drinking Water and Toxic Enforcement Act of 1986 (Proposition 65) requires the Governor of California to publish a list of substances known to the State of California to cause cancer or reproductive harm, and requires businesses to warn customers of potential exposures to such substances. Users of this appliance are hereby warned that when the oven is operated, there may be some low-level exposure to some of the listed substances including carbon monoxide. Exposure to these substances can be minimized by properly venting the oven or by opening the windows and/or doors in the room where the appliance is located. This appliance should not be operated without a properly sized and functional ventilation hood.

**WARNING**

To reduce the risk of appliance tipping, it must be secured to the wall with a properly installed anti-tip bracket. To make sure the bracket has been installed properly, inspect behind the range using a flashlight.

- Anti-tip devices are only necessary for range products
- This range can tip causing personal injury
- See Installation Instructions supplied with the range and install the anti-tip device packaged with the range
- If the anti-tip device cannot be located, contact American Range Customer Service by calling 818.897.0808 or by contacting us at www.americanrange.com

 **CAUTION**

Purchase a kitchen fire extinguisher for your home and store it in close proximity to your appliance. Should an uncontrolled fire occur, never use water on grease fires. Never pick up a flaming pan. The oven door interior and exterior, especially the oven door glass can get hot during operation. Do not touch the glass – use the door handle to open or close the range door.

The push-to-turn gas valve knobs on the appliance are designed to be child-safe, however, they are not a guarantee of operation. Children should not be left alone or unattended in the kitchen while the appliance is in use. Never leave the appliance unattended during use. Boil-overs may occur, causing spills which may ignite.

Never wear loose fitting or long sleeved apparel while cooking. Never wear garments made of flammable materials. Clothing may ignite or catch utensil handles. **DO NOT** drape towels or other items on door handles. These items could ignite and cause burns.

If your product is a range or oven **ALWAYS** place oven racks in the desired position before you start cooking and while the oven is cool. Always use dry and sturdy pot-holders to carefully slide the oven rack out to add or remove food.

If your product is a range or cooktop located near a window, be certain window curtains or other flammable objects do not blow over or near the range burners; the items could catch on fire.

If operating the surface burners, the flame should be adjusted to just cover the bottom of the pan or pot. Excessive high flame settings may cause scorching of the nearby counter-top surface, as well as the outside of the utensil and handles.

ALWAYS turn the appliance off at the end of cooking.

When dehydrating food items, periodically check during the process to ensure that they do not catch on fire.

If you are "flaming" liquor or other spirits under an exhaust, **TURN THE FAN OFF**. The draft from the fan could cause the flames to spread out of control.

Care should be exercised if your appliance is equipped with a high-shelf. During heavy or continuous use, this shelf may become hot. Do not place combustible materials or plastic items on the shelf.

Turn the knobs to the **OFF** position prior to removing them from the valve stems for cleaning.

 **WARNING**

NEVER use this appliance as a space heater to heat or warm the room; doing so may result in carbon monoxide poisoning and overheating of the appliance. Do not use the range top or oven as a food or kitchen item storage area.

Never block or cover any slots, holes or passages located anywhere inside or outside the range. These structures are important to safe operation of the appliance and doing so may block airflow through the oven or cook top possibly causing carbon monoxide poisoning or fire. Routinely keep all slots free of grease and other materials.

This appliance has been tested for safe performance using conventional cookware. **DO NOT USE** any device or accessory not specifically recommended in this guide. **DO NOT USE** pan or pan covers on surface units, grills or griddles. These devices can create serious safety hazards including personal injury, create performance problems and may damage the appliance. Do not store or use corrosive chemicals, vapors, flammables or non-food products in or near this appliance. It is specifically designed for use when heating or cooking food. The use of corrosive chemicals while heating or cleaning could result in personal injury or damage to the appliance.

INSTALLATION INSTRUCTIONS

The location selected for the range must meet the following criteria. If any of these criteria are not met, select another location.
Important - The maximum depth of the overhead cabinets installed on either side of the hood is 13".

SITE PREPARATION

- The range is a free standing appliance. If the range is to be installed adjacent to cabinets, the clearances where indicated are required.
- This range may not be recessed into the cabinets. The rear of the oven door must be beyond the edge of the front face of the adjacent cabinet.
- The gas and electrical supplies should be located below the unit or in the adjacent right cabinet.
- Any openings in the wall behind the range and in the floor under the range must be sealed.
- Always keep the appliance free and clear of combustible materials, gasoline, or other flammable vapors and liquids.
- Do not obstruct the flow of combustion exhaust and ventilation air to the unit.

CABINET PREPARATION

- Check cabinet materials to be sure they can be used in proximity of the Range.
- The maximum depth of overhead cabinets installed on either side of the hood is 13".
- When there is less than 12" clearance between combustible material and the back edge of the Range above the cooking surface, a backguard must be installed.
- When clearance to combustible material is over 12" no backguard is necessary.
- Backguards must be ordered separately.

ELECTRICAL CONNECTION

- The Range must be electrically grounded in compliance with local codes or, in the absence of local codes, with the National Electrical Code, ANSI/NFPA70.
- This range requires a 120 volt supply to operate the ignition system. The supply cord provided on the range is equipped with a three-prong (grounding) plug for protection against electrical shock.
- The electrical service in the building must be equipped with a properly grounded three-prong receptacle.
- Do not cut or remove grounding prong from this plug.**

POWER REQUIREMENTS FOR THIS RANGE

- 120 VAC, 60 Hz, single phase, 15 AMP Max

GAS CONNECTION

Be certain the appliance gas type matches the gas service being provided. Refer to the appliance rating label for the gas supply requirements.

A manual gas shut-off valve must be remotely installed and easily accessible in the adjacent cabinet. The regulator inlet is for a 1/2" gas line.

- Use at least a 1/2" inside diameter commercial flex hose to connect range to the gas supply (service line).
- A manual gas shut-off valve must be installed, in easy access in front of the gas supply (service line) and ahead of the range for safety and ease of maintenance.
- All valves must be in the OFF position before connecting to the gas supply line.

INSTALLATION INSTRUCTIONS

PRESSURE REGULATOR

- The regulator installed in the range is adjusted at the factory for 5" WC (natural gas) or 10" WC (L.P.) depending on the customer's request. Regulators must not be removed.
- The regulator can withstand a maximum pressure of 1/2 PSIG (14" WC). If the line pressure is beyond this limit, a step-down regulator will be required.
- Any adjustment to regulators must be made **ONLY BY QUALIFIED** service personnel with proper test equipment.

GAS REQUIREMENTS

- Ensure supplied gas matches the range's gas type.
- Natural gas connection is 1/2" N.P.T. minimum 1/2" inside dimension diameter flex line.
- Natural gas inlet pressure to measure 7" to 10" W.C.
- Propane gas connection is 1/2" N.P.T. minimum 1/2" inside dimension diameter flex line.
- LP gas inlet pressure to measure 11" to 14" W.C.
- A step-down regulator is required at the LP (Propane) source to limit pressure to a maximum of 14" W.C. operating with the appliance regulator provided with the LP range.

Check that all gas connections are properly sealed with a suitable gas joint compound.

TEST FOR GAS LEAKS WITH A SOAPY WATER SOLUTION BEFORE LIGHTING THE BURNERS.

1. Turn ON the manual gas valve at the inlet side of the gas supply line.
2. Check for gas leaks at the flexible coupling or gas connector fitting using a solution of one part soap and three parts water.
3. Sparingly spray or brush the soapy solution at the gas fittings; active bubbling indicates location of gas leak.
4. If a gas leak is detected turn off the manual gas valve at the inlet side of the gas line. Call your certified service technician.

FLEXIBLE COUPLINGS, CONNECTORS AND CASTERS

- Flexible couplings and/or quick-disconnect fittings must be heavy duty, CSA/UL design certified of at least 1/2" NPT with suitable strain reliefs.
- The flexible connector must comply with the standard for Connectors for Movable Gas Appliances, ANSI Z21.69-CSA 6.16 and any Quick-Disconnect Devices For Use With Gas Fuel Appliances should comply with ANSI Z21.41CSA 6.9.
- All connections must be sealed with joint compound specified for LP or Natural gas; and all connections must be tested with a soapy water solution before using.
- When disconnection of the restraint is necessary, make sure to reconnect restraint after the range has been returned to its original position.

RATING PLATE - The information on the rating plate defines the model, serial number, gas type (natural or liquid propane), operating pressures and burner BTU ratings. Keep this information for future reference. It is essential for proper identification of the unit when requesting additional information or factory support.

Intertek 3013256 MODEL NO. ARR-304IS		American Range (www.americanrange.com) 13592 DESMOND ST., PACOIMA, CA 91331 GAS TYPE XXX MAN. PRESS. XXX IN W.C. X.X	
SERIAL NO. XXXXXX-XXX		BTU INPUT/HR/SECTION	
COOK TOP Large 17,000 Medium 13,500 Small 9,000	GRILL 		
VOLTS 120 AMPS 9 OVEN BK 18 	BROIL 18 		
CYCLES 60 PHASE 1 BK 24,30,36 30,000	BR 24,30,36 15,500		
ANSI Z21. 1b - 2003 HOUSEHOLD COOKING APPLIANCES		GRIDDLE 	

Rating Plate

INSTALLATION INSTRUCTIONS

WARNING

Do not use the handle or oven door to lift the oven. Remove range door before installation to ensure that it is not used to lift the unit. Make sure the hinge catch is fully open or closed before removing door to prevent injury to hands and/or fingers.

- Do not remove protective packaging until you are ready to perform the installation.
- Do not remove the protective wrapping from the product control panel until the product is installed.
- Caution - the appliance is heavy. Use extreme care when handling!
- Use proper equipment to move products.
- Any openings in the wall and in the floor behind or under the oven must be sealed.
- Do not use an extension cord with this appliance. Such use may result in fire, electrical shock or other personal injury.
- Installation of this appliance should be performed by qualified, licensed contractors.
- To remove the packaging, first remove the staples located at the bottom perimeter of the corrugated cardboard cover.
- Remove the corrugated cardboard carton by lifting it off the product and remove the inner packing.
- Detach the product from the metal anchor strip by removing the attachment screw.
- Confirm available access to adequate power and gas. See Specifications & Electrical Requirements table.
- Fill out the inside cover of this installation manual with the requested data. Model Number and Serial Number can be found on the plate located underneath the control panel on the front of the appliance.

WARNING

For optimal performance, the range should be installed away from drafts that may be caused by doors, windows, and heating and air conditioning outlets.

OVERALL DIMENSIONS HERITAGE GAS RANGES

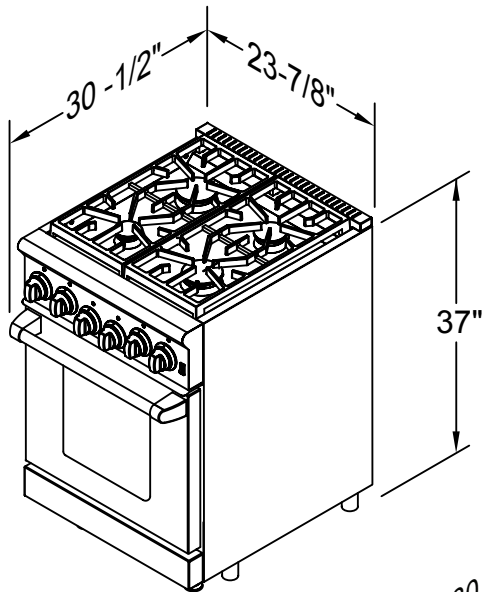

24" Range

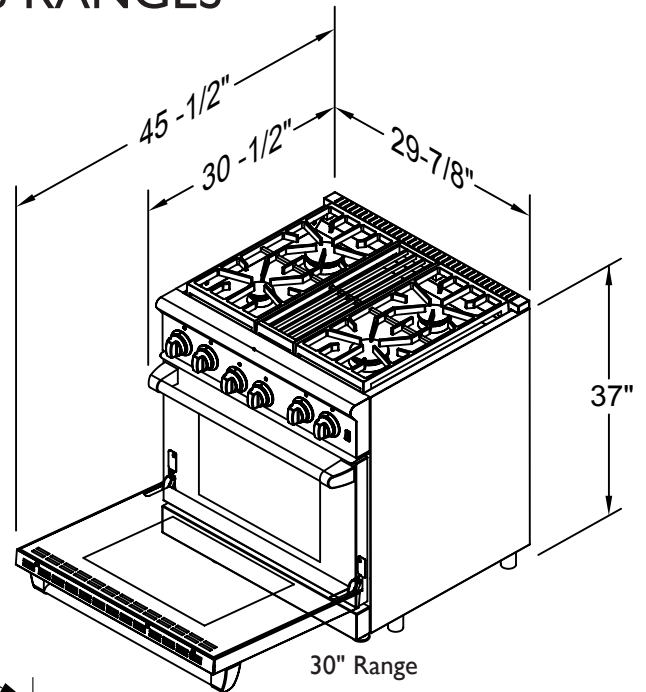

30" Range

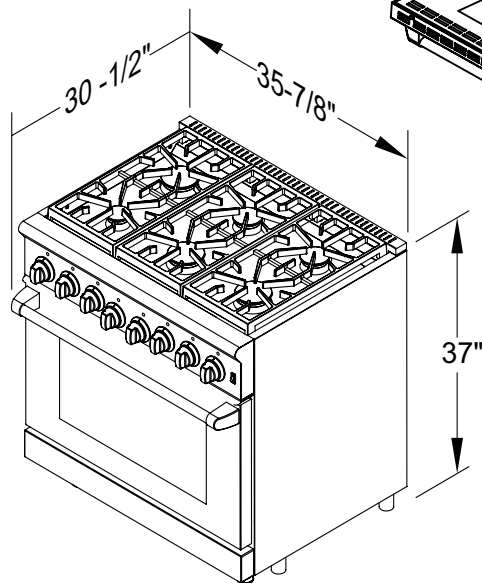

36" Range

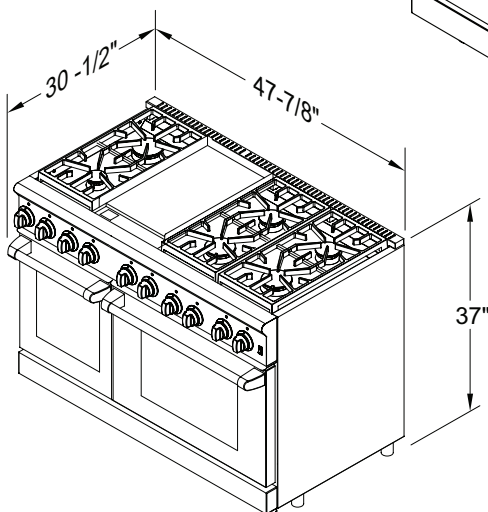

48" Range

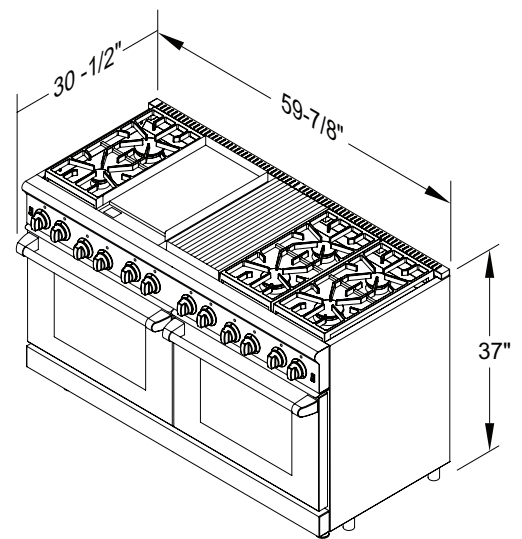

60" Range

OVERALL DIMENSIONS HERITAGE GAS RANGES

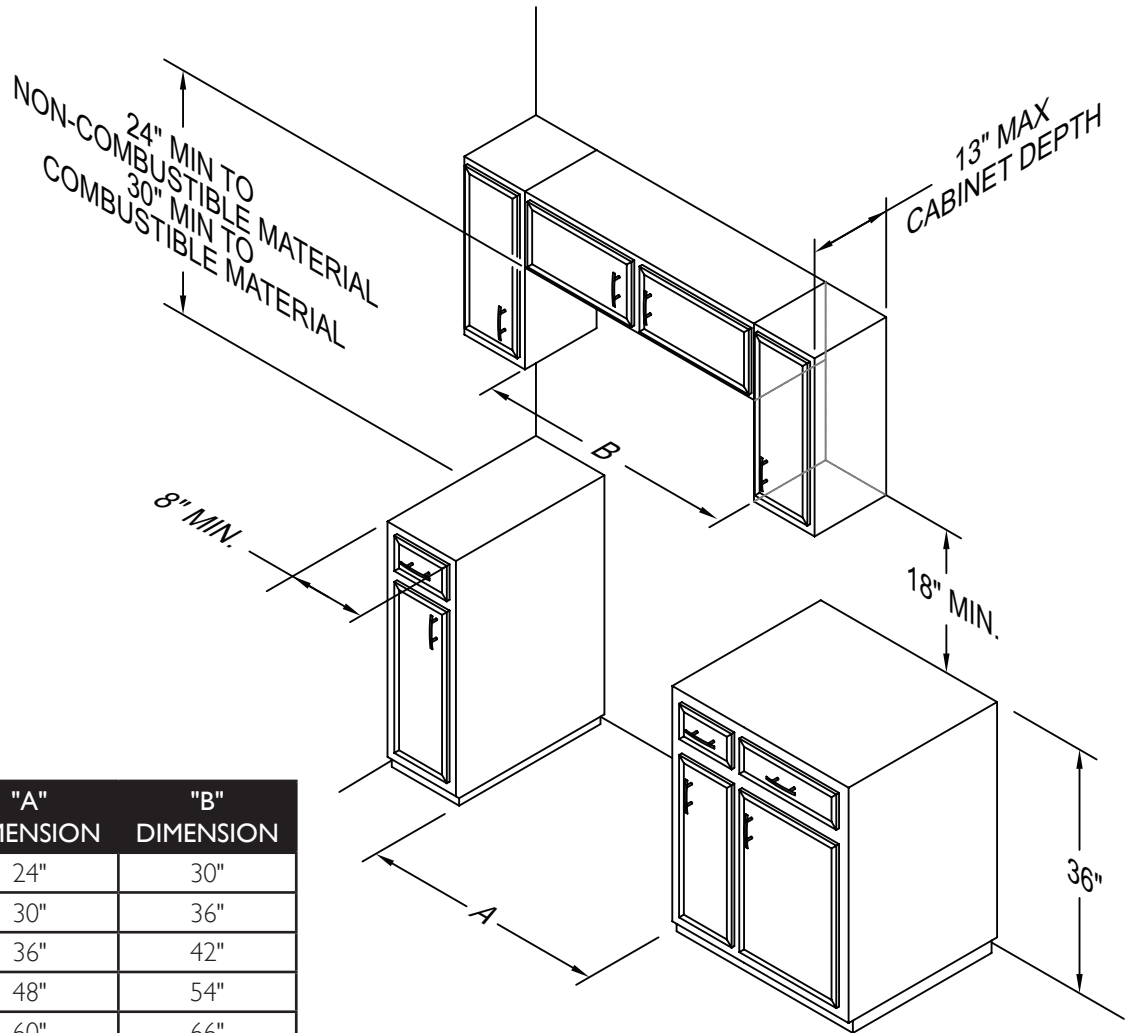

RANGE WIDTH	"A" DIMENSION	"B" DIMENSION
23-7/8"	24"	30"
29-7/8"	30"	36"
35-7/8"	36"	42"
47-7/8"	48"	54"
59- 7/8"	60"	66"

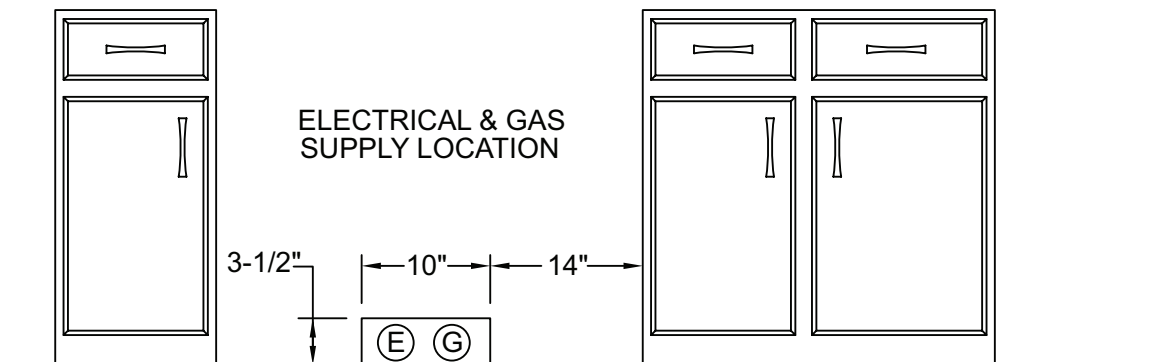

OVERALL DIMENSIONS TITAN GAS RANGES

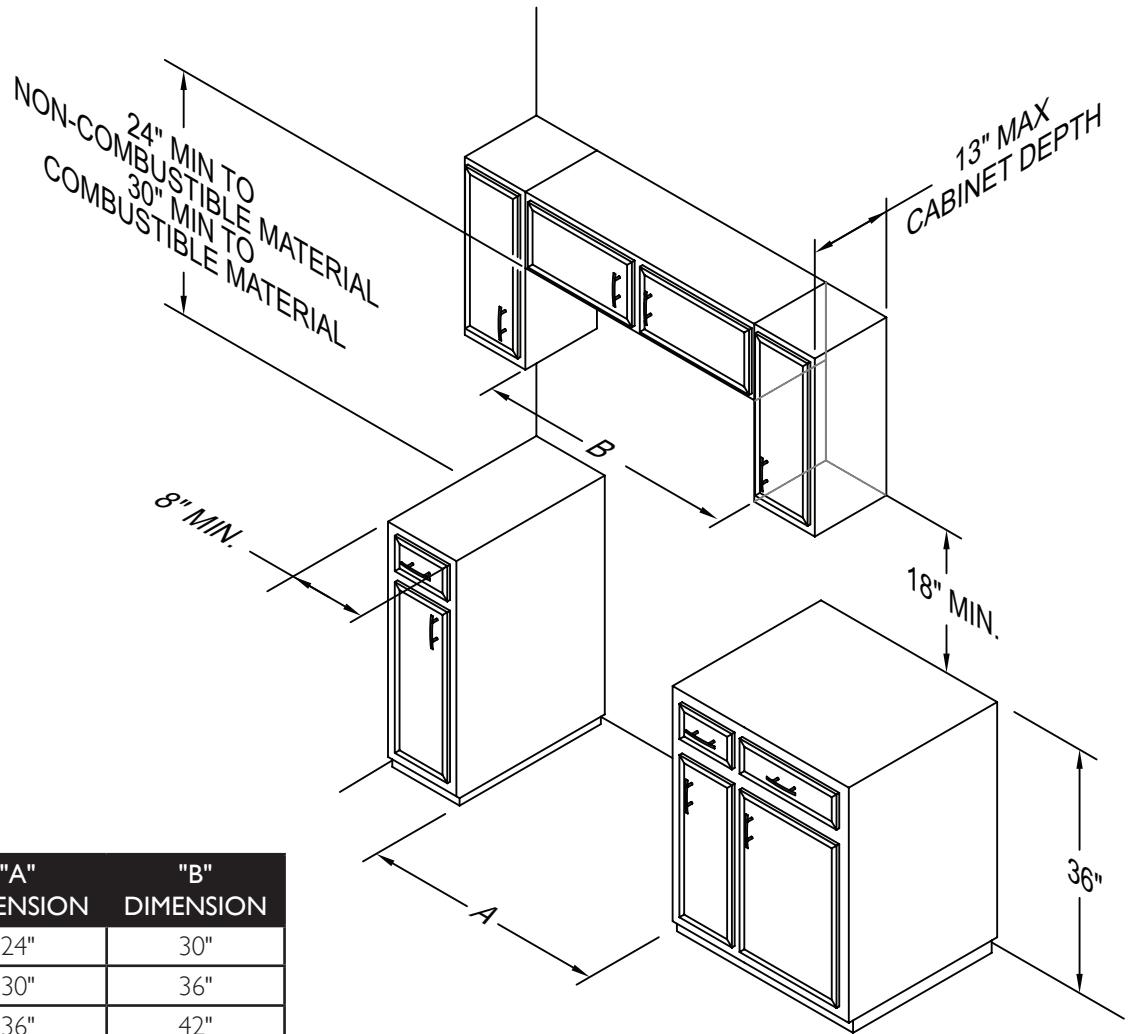

RANGE WIDTH	"A" DIMENSION	"B" DIMENSION
23-7/8"	24"	30"
29-7/8"	30"	36"
35-7/8"	36"	42"

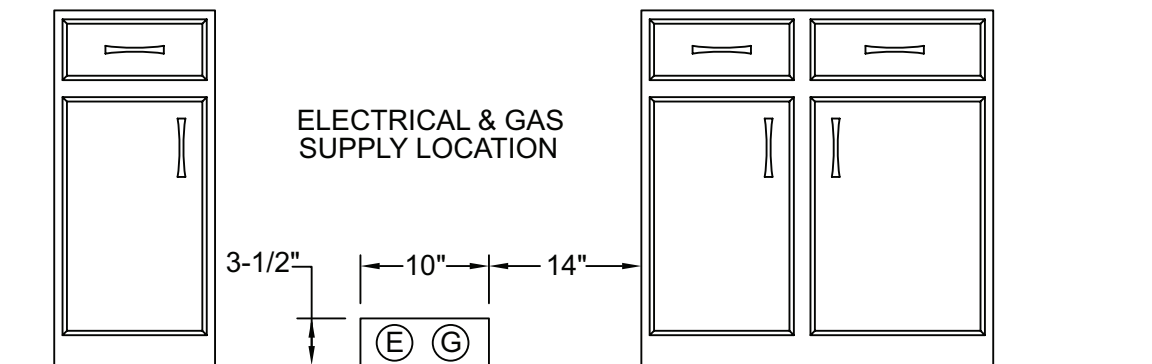

HERITAGE - VENT HOOD CLEARANCE DIMENSIONS

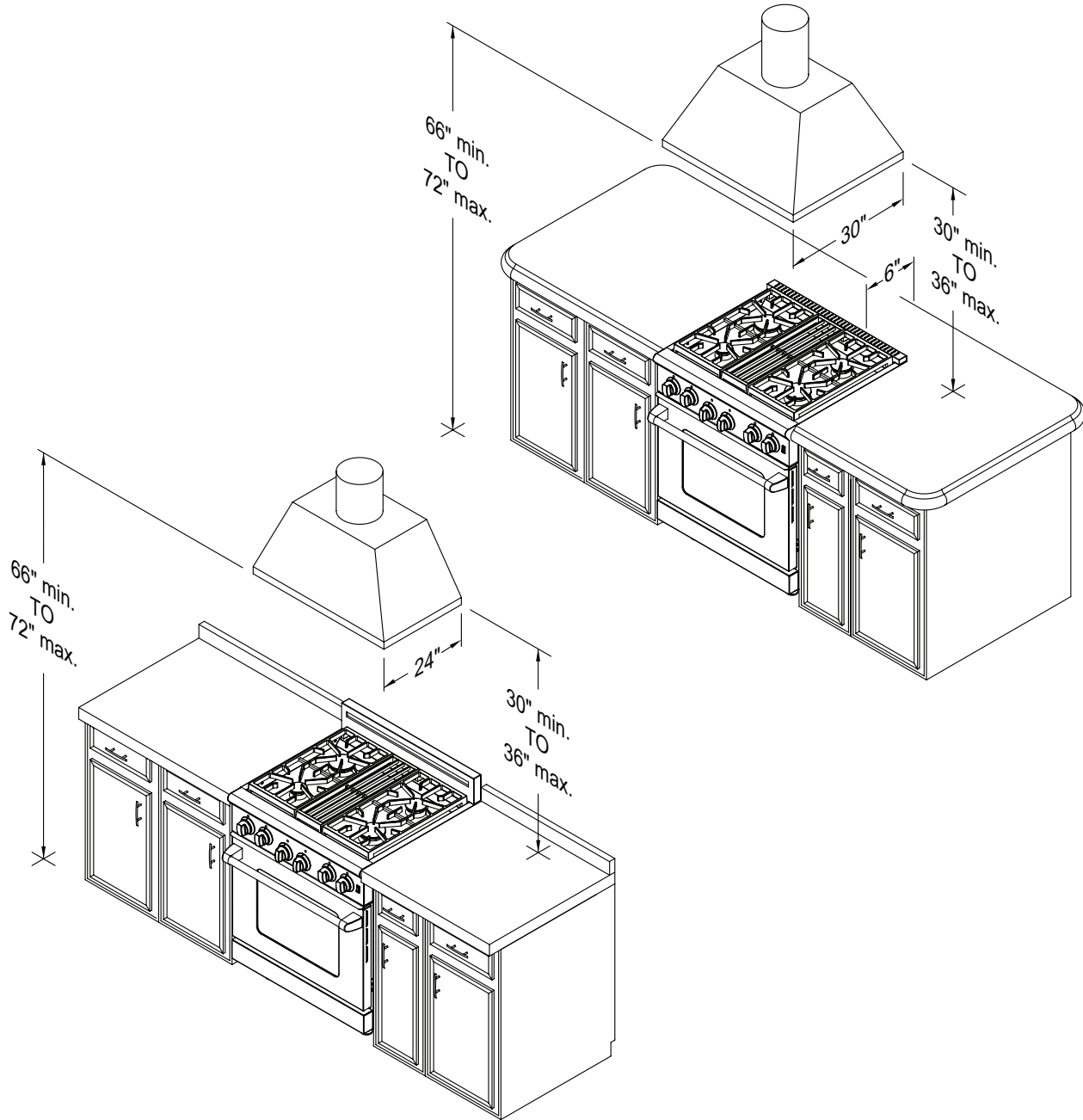

VENT HOOD REQUIREMENTS & RECOMMENDATIONS

UNIT	STANDARD COUNTER	ISLAND INSTALLATION
	24" Deep	30" Deep
48" Range	800-1200 CFM	800-1200 CFM
36" Range	600-800 CFM	600-1200 CFM
30" Range	500 CFM	500 CFM

TITAN - VENT HOOD CLEARANCE DIMENSIONS

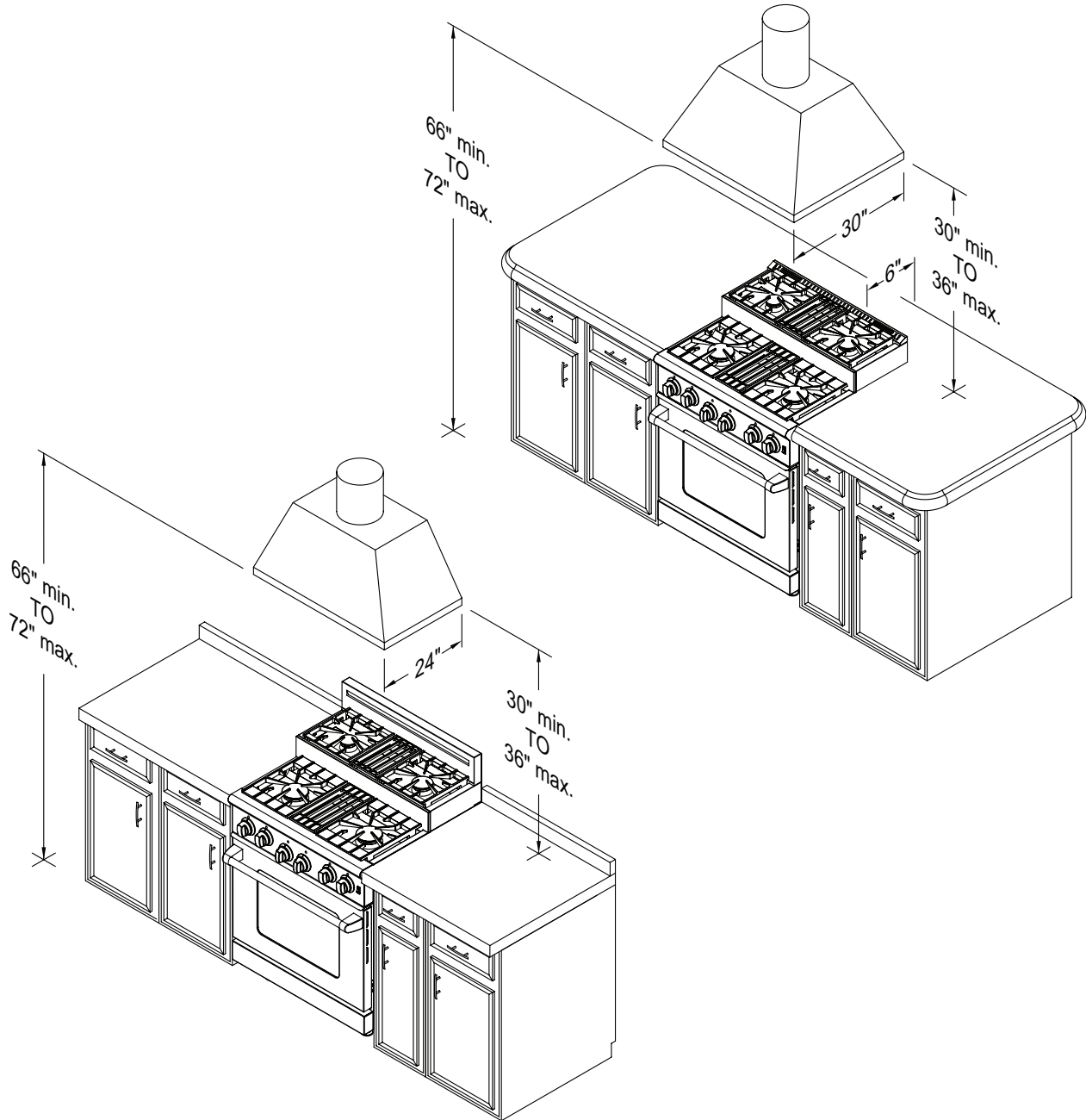

VENT HOOD REQUIREMENTS & RECOMMENDATIONS

UNIT	STANDARD COUNTER	ISLAND INSTALLATION
	24" Deep	30" Deep
48" Range	800-1200 CFM	800-1200 CFM
36" Range	600-800 CFM	600-1200 CFM
30" Range	500 CFM	500 CFM

OVERALL DIMENSIONS HERITAGE GAS RANGES

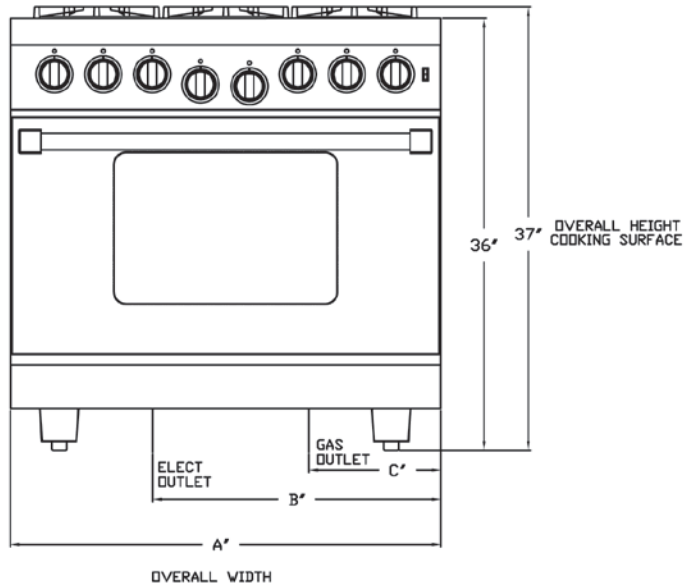

UNIT	"A" IN.	"B" IN.	"C" IN.
24"	23.875	18	11
30"	29.875	20-1/2	11
36"	35.875	24	11
48"	47.875	20-1/2	11
60"	59.875	20-1/2	11

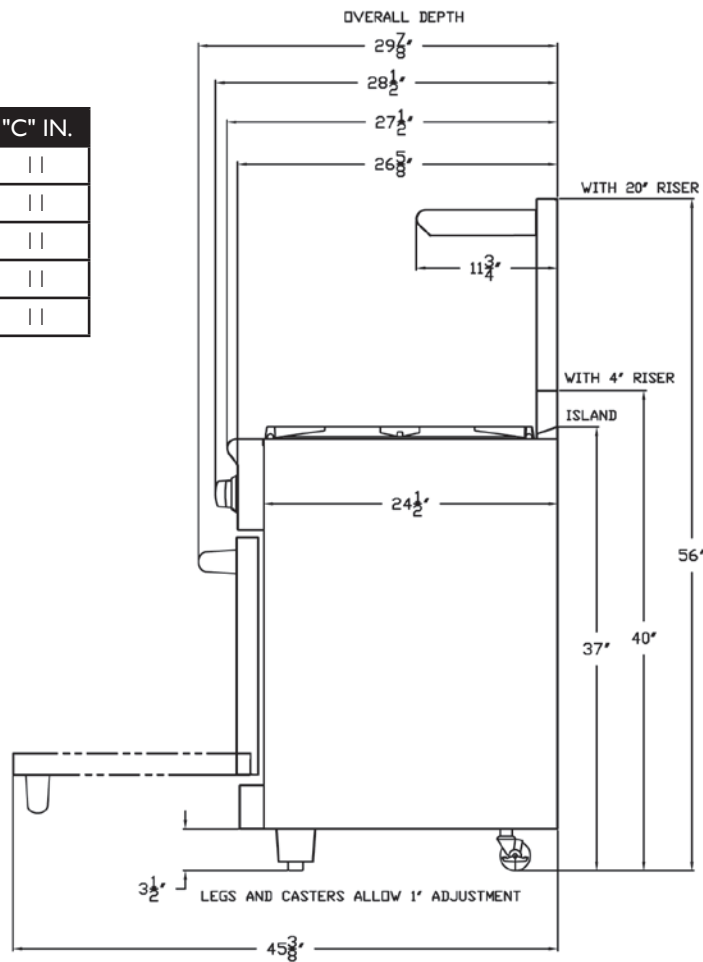

OVERALL DIMENSIONS TITAN GAS RANGES

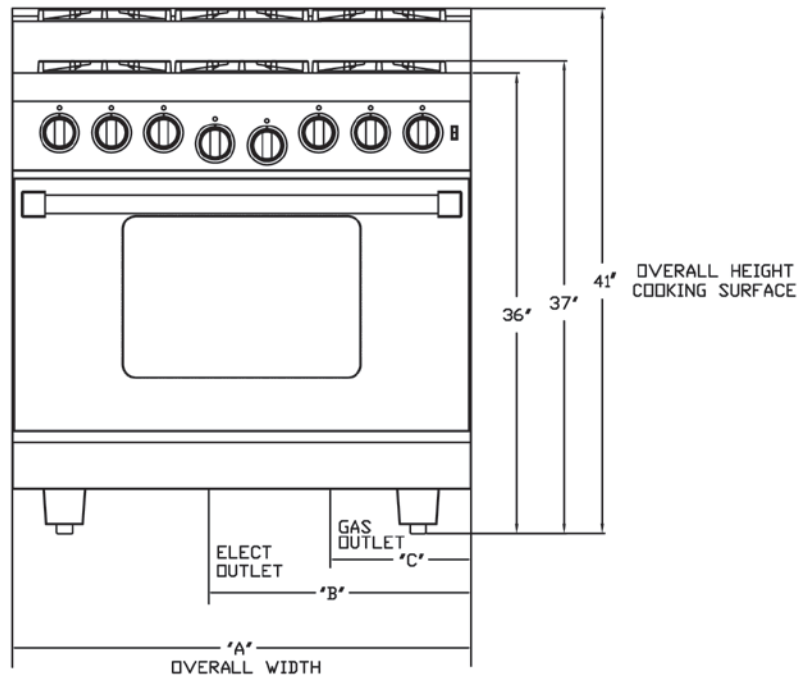

UNIT	"A" IN.	"B" IN.	"C" IN.
24"	23.875	18	11
30"	29.875	20-1/2	11
36"	35.875	24	11
48"	47.875	20-1/2	11
60"	59.875	20-1/2	11

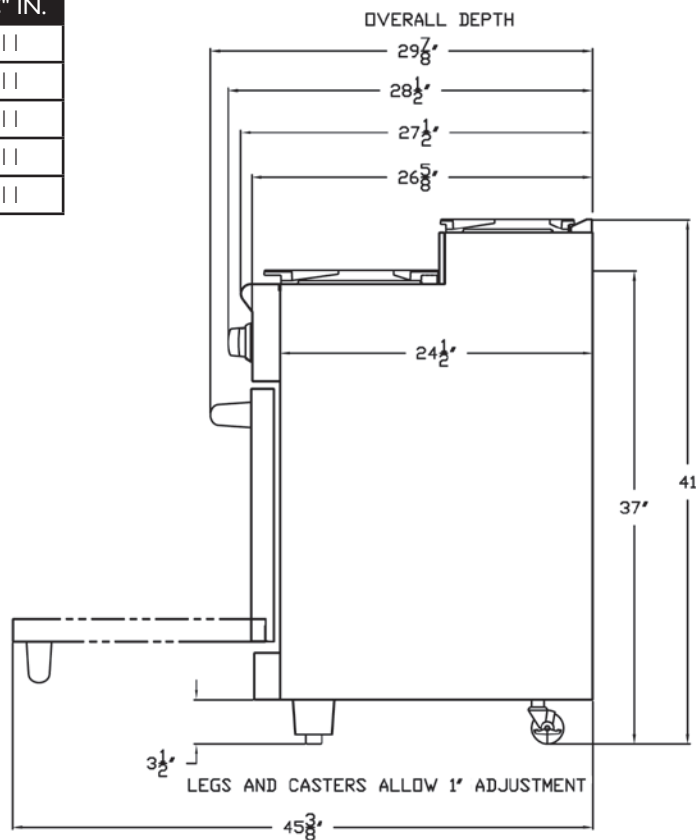

TYPICAL MODEL & PARTS IDENTIFICATION

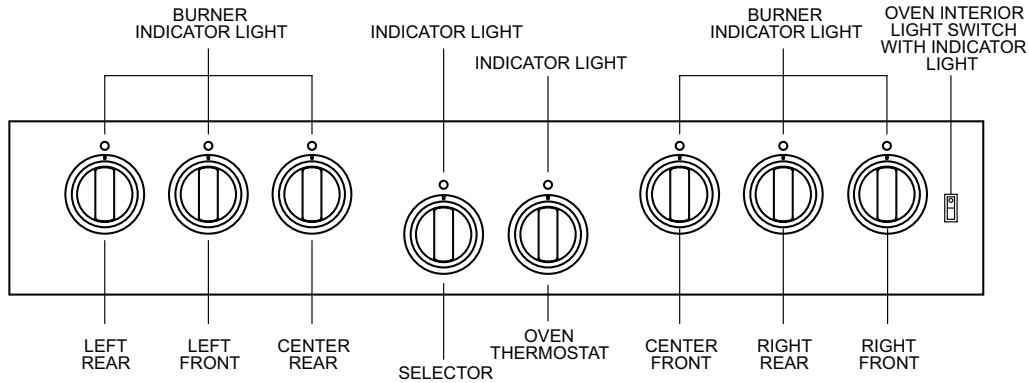

HERITAGE

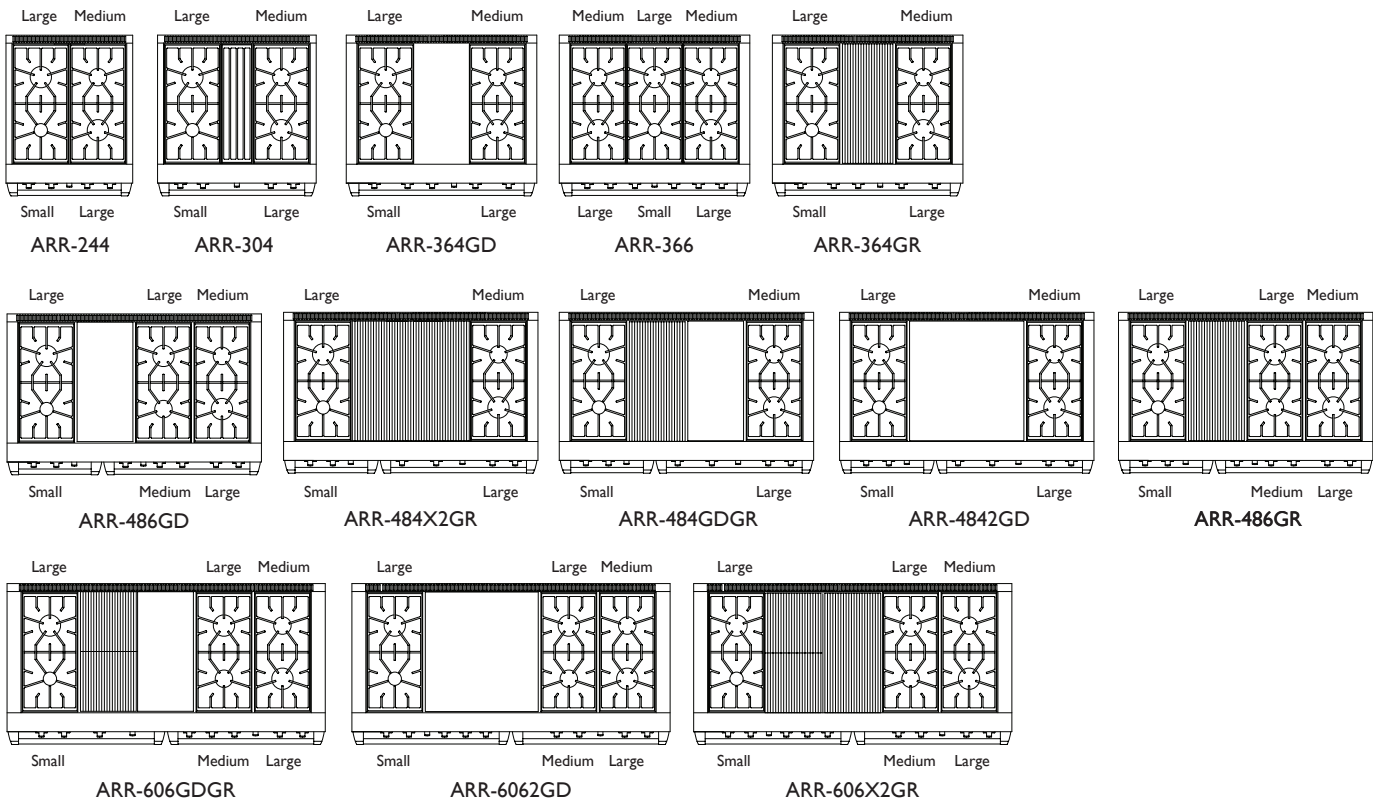

TITAN

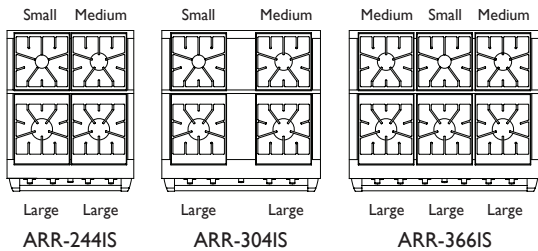

3 SIZES OF BURNERS:
 Large Burner 17,000 BTU
 Medium Burner 13,000 BTU
 Small Burner 9,000 BTU

MODEL AND PARTS IDENTIFICATION

DESCRIPTION	HERITAGE SERIES - GAS RANGES														TITAN RANGES	
	ARR-244	ARR-304	ARR-364GD	ARR-366	ARR-364GR	ARR-486GD	ARR-484X2GR	ARR-484GDGR	ARR-4842GD	ARR-486GR	ARR-6062GDGR	ARR-6062GD	ARR-606X2GR	ARR-244IS	ARR-304IS	ARR-366IS
Oven Racks	2	2	2	2	2	4	4	4	4	4	4	4	4	2	2	2
Sealed Burners	4	4	4	6	4	6	4	4	4	6	6	6	6	4	4	6
Fixed Rack Guides	2	2	2	2	2	4	4	4	4	4	4	4	4	2	2	2
Center Grate	0	1	0	0	0	0	0	0	0	0	0	0	0	0	0	0
Burner Grates	2	2	2	3	2	3	2	2	2	3	3	3	3	4	4	6
Burner Caps	4	4	4	6	4	6	4	4	4	6	6	6	6	4	4	6
Control Knobs	6	6	7	8	7	11	10	10	10	11	12	12	12	6	6	8
Griddle	0	0	1	0	0	1	2	1	2	0	1	2	0	0	0	0
Stainless Radiant	0	0	0	0	1	0	2	1	0	1	1	0	2	0	0	0
Backyard Grill	0	0	0	0	1	0	2	1	0	1	1	0	2	0	0	0
Regis. Card	1	1	1	1	1	1	1	1	1	1	1	1	1	1	1	1
Island Trim	1	1	1	1	1	1	1	1	1	1	1	1	1	1	1	1
U&C Manual	1	1	1	1	1	1	1	1	1	1	1	1	1	1	1	1
Anti-Tip Device Kit	1	1	1	1	1	1	1	1	1	1	1	1	1	1	1	1

Oven Racks: Each oven is supplied with two heavy chrome-plated adjustable oven racks.

Rack Supports: On each side of the oven, heavy chrome-plated rack supports allow five positions, numbered from the bottom up.

Oven Knob: The oven knob is used to set the Baking temperature or to select the Broil function. During baking, the convection fan may be activated.

Bake Burner: The Bake burner is located in the center of the oven, below the floor and is activated by the Oven Control Knob.

Inconel® Infrared Broil Burner: Positioned in the oven ceiling, burning gas heats the Inconel® screen to a temperature of 1,850°F – creating searing heat similar to the glowing coals of a wood fire.

Broil Burner Igniter: The igniter glows a very hot, bright red-orange color, reaching proper ignition temperature to light the Inconel® Infrared Broil Burner.

Burner On Indicator Light: Whenever an oven burner is activated (either Bake or Broil), the burner on indicator will glow. It is normal for the indicator light to cycle off and on during baking or broiling – showing that the requested temperature has been achieved – or that more heat is required.

Door Gasket: The door gasket is made from high temperature materials and creates a seal between the hot oven and the cool kitchen.

Convection Mode: Operated by the selector knob, the convection fan circulates oven air, removing the “thermal boundary layer” on items being baked – and in doing so – speeding up heat transfer and reducing cook time by as much as 25%. Convection can only be activated during baking.

Oven Light and Switch: Two lamps are provided in the oven to illuminate baked and broiled food items, as well as shed some light on the oven walls to help during clean-up.

INSTALLATION CHECKLIST

This checklist has been developed to assure proper installation of your oven.
 To validate warranty, you must mail, e-mail or fax this form and a copy of your receipt to:
AMERICAN RANGE CUSTOMER SERVICE, 13592 DESMOND STREET, PACOIMA, CA 91331
service@americanrange.com
818.897.8839 FAX

Street: _____ Purchase Date: _____

City, State, Zip Code: _____ Installation Date: _____

E-mail: _____ Installer's Name: _____

Telephone: _____ Company: _____

Dealer: _____ Telephone: _____

CHECK ALL THAT APPLY

Appearance and Aesthetics

- Exterior
- Top section
- Oven interior
- Anti-Tip Bracket

Electrical Connection

- Correct voltage
- Grounded outlet
- Polarized outlet
- No GFCI

Installation

- Read User Manual
- Review Safety Instructions
- Proximity to cabinets
- Backguard in place
- Level
- Ventilation system

Gas Connection

- Verify fuel: Natural -or- LP
- Gas shut-off present and accessible
- Gas Supply line properly sized
- Gas Supply pressure checked
- Operating pressure checked
- All connections checked for leaks

Ignition

- Top Burners
- Griddle
- Char Broiler
- Oven Burner
- Infrared Broiler

Flame Adjustment

- Top Burners
- Griddle
- Char Broiler
- Oven Burner

Air/Gas Mixture

- Top Burners
- Griddle
- Char Broiler
- Oven Burner

Valve Operation

- Top Burners
- Griddle
- Char Broiler
- Oven Burner

Controls

- Burner Knobs
- Thermostats
- Char Broiler
- Convection Oven Fan
- Oven Light Switch

Oven Door

- Alignment
- Door Seal
- Hinges

Customer Copy



PERFORMANCE CHECKLIST

A qualified installer should carry out the following performance checks referring to the User Manual as necessary:

- Check operation of oven setting BAKE at 350°.
- Check operation of BROIL function.
- Check operation of all top burners at high and low flame.
- Check operation of oven light using front panel control switch.
- Check operation of the convection fan by turning selector knob to fan mode.
- Check operation of all indicator lights on control panel.

RANGE START-UP PROCEDURE

Before cooking in your oven for the first time remove oven racks and wash them with hot soapy water. Thoroughly rinse, dry and replace them in the oven.

During initial start-up of the oven, after all performance checks and adjustments have been made, the oven should be allowed to burn off any oils or solvents left from the manufacturing process. In any case, these materials are safe for the environment – but it is best they not contribute to the taste or odor of your first oven cooking experience.

OVEN BURN-OFF PROCEDURE

- Turn on the kitchen ventilating hood.
- Light the oven according to the instructions in the manual.
- Set the oven thermostat temperature to 350°F.
- Let the oven run for one hour.
- Turn on the convection fan.
- Set the oven thermostat to 450°F.
- Leave the oven operational for an additional hour.
- Shut-off the oven by turning the thermostat to the OFF position.

BROILER BURN-OFF PROCEDURE

- Turn on the kitchen ventilating hood.
- Light the broil burner according to the instructions in the manual.
- Operate the broiler for ten minutes.
- Open the door briefly – about ten seconds.
- Operate the broiler for an additional ten minutes.
- Shut-off the broiler by turning the thermostat to the OFF position.

During the oven or broiler burn-off process, some strong odors or minor smoke may be experienced as remaining oils or solvents on internal parts are oxidized. This is the primary reason for the burn-off process and should dissipate by the completion of the time period.

OPERATING INSTRUCTIONS

BEFORE USING THE NEW COOK TOP

- Before using the cook top for the first time, wash the outside area with soap and water to remove any shipping and factory residue.
- The burner grates are designed in sections and are easy to remove and clean. They are made of cast iron with a porcelain coating and will remain hot after the burner is turned off creating a residual heat for continued cooking. Use caution when handling.
- Your new professional Range is equipped with burners that are similar to those used in restaurants.
- The burner heads are designed to ensure even heat distribution for better cooking. They must be in place and properly seated before lighting.
- The Range must not be operated without the burner heads.
- There are no continuously burning pilot lights. An electronic spark ignition system is used to light the burner. If the flame should go out from a boil-over or a strong draft, the burner will automatically reignite.

OPERATION OF THE BURNERS

1. Press in on the knob that corresponds to the burner that you would like to light. Use the front panel graphic to confirm your selection until you become familiar with the range. Turn the knob counter-clockwise to the "American Flame" icon located on the knob – this is the light position of the burner valve.
2. The igniter for all the surface burners will begin sparking – however, gas will flow to only the selected burner.
3. After the burner lights, the igniter clicking will stop – indicating that the flame sensing and re-ignition system is active on the selected burner.
4. Rotate the knob to any flame setting that you desire between MAX and SIMMER. The blue panel light will remain lit until the valve is returned to the OFF position.

The surface burners are rated at different power levels:

BURNER TYPE	SMALL	MEDIUM	LARGE
Sealed Burners	9,000 BTU/hr.	13,000 BTU/hr.	17,000 BTU/hr.

When you are using the surface burners, select the burner power and location depending on the heating or cooking function you would like to perform.

A normal flame is blue in color and steady. Foreign materials in the kitchen air or the gas line, especially in new construction installations, may cause some orange color bursts during initial operation. This will disappear with continued use. Small yellow tips on the ends of flames are normal when using LP gas.

If the flames look odd (too small, too large, lazy or drifting, uneven around the burner circle, etc.) check to see that the burner head is seated correctly on the burner base. Do this when the burner is cold by gently rocking the burner head or rotating the head from side to side. If it is correctly seated, it will nest in detents. If this does not correct the problem, turn to the Troubleshooting section of this manual.

AUTO RE-IGNITION

The surface burners are equipped with a special ignition and re-ignition system that senses the presence of flame and re-ignites the burner should the flame disappear while gas is still flowing to the burner.

Strong drafts, spills and general grime influence the operation of the automatic re-ignition system – a clean system will generally function better than a dirty system. Periodically, remove any materials or grime that might build up on the high voltage spark electrode – using a toothbrush or other non-metallic cleaning utensil.

COOKWARE RECOMMENDATIONS

To avoid the risk of serious injury, damage to the range or cookware, please observe the following guidelines.

Bakeware, such as large casserole pans, cookie sheets, etc., should never be used on the cook top.

Placement of large stock pots should be staggered when used on the cook top. Select the base diameter of the pot to match the diameter of the flame. The diameter of the flame and the diameter of the pan bottom should match or be slightly smaller. The use of pots too large or too small will compromise cooking performance.

Do not place food packaged or wrapped in aluminum foil directly on the burner grate above the burner. Aluminum foil can melt during cooking.

Be careful to not let plastic, paper or cloth come in contact with a hot burner grate. These materials can catch fire or melt.

Never let a pan boil dry – and if it occurs remember it can be extremely hot – and very dangerous. If this should occur, turn off the burner immediately. Wait a while, until the pot cools down enough to handle – this could be several minutes, but could save you from burns or other serious injury.

The pan bottom should be flat, the heavier the better – and well balanced on the cook top grate – sitting flat without rocking – preferably with tight fitting lids. Try not to slide the pot across the grates – while it is very handy to do so – you may end up scratching the pot or the grate.

Always be careful when using high flames, as in wok cooking, as they may contact flammable materials or make the handles of the wok very hot. Use the wok ring (optional) to stabilize the wok.

SUGGESTED BURNER SETTINGS	
HEAT SETTINGS	USE
Simmer	Melting small quantities of butter, simmer grains, rice, oatmeal
Low	Poaching eggs, fish, poultry
Low - Medium	Fry eggs, heat milk, cream sauces
Medium	Puddings, custards, gravies
Medium High	Sauté vegetables, braise meats, soups and stews, deep fat frying, boiling water and pasta, blanching vegetables, searing meats
High	Large quantity of water to boil, large quantity frying and cooking

OVENS 101

The oven is a gas fired, temperature controlled cooking cavity which is highly insulated to keep the kitchen cool and the food hot. The oven contains two burners - the Bake burner positioned below the oven floor and the Broil burner located in the ceiling of the oven. Bake and Broil are very different cooking operations and the burners are designed to deliver energy in a way appropriate to the task.

There are two types of baking - called Standard Bake and Convection Bake. Standard or conventional baking makes best use of Grandma's cookie, cake or pie recipes – like Bake at 350°F for forty-five minutes – to get the job done. These recipes are tried and true – standard bake will deliver wonderful performance every time you cook.

When you convection cook (using a fan to circulate the high temperature air inside the oven) you can lower the thermostat about 25° and reduce the cook time by about 25% - and achieve fine cooking results just like Grandma's – taking less time and using less energy. Use the same recommended temperatures for meats and poultry dishes – but keep watch of the time. Convection cooking technology was first developed in Europe and has been used for many years – recently taking hold in US residential kitchens and cookbooks.

In convection cooking, not only is the cook time faster, but also, the oven temperature is more even, top to bottom and side to side – so cookies on several racks will have the same brown color and texture. However, to best take advantage of convection, use low, shallow bakeware so that moving air can get over the sides and up to the food surface. Foods in covered dishes (like casseroles or pot roasts) do not benefit from convection cooking.

To get started, remove all plastic wrappers used to protect the finish of the Stainless Steel surfaces. If you do not, the wrapper may get stuck on the Stainless Steel when the oven is hot – making removal later very difficult.

Although care is taken at the factory to remove processing oils, consider a final wipe down using a soft cloth and hot, soapy water, well rinsed and dried from the surface.

OVEN OPERATION

To light the oven, push in and turn the selector knob to Bake or Convection Mode and turn the thermostat knob to the desired operating temperature from 150°F to 500°F. You may be able to see a bright glow from the sides of the oven bottom – this is normal and indicates the hot surface igniter is activated. Once the igniter is hot enough for ignition, the gas valve will open, allowing the flow of gas into the bake burner. This may take up to just one minute.

During the first few minutes of operation, a mild condensation may appear on the interior glass pane of the door window. Water vapor is a normal by-product of combustion, and the condensation will disappear as the oven warms.

If you would like to bake using the Convection feature, you may turn on the fan at any time – allowing the oven about twenty or thirty minutes to preheat before use.

Never place any pan or food item on the bottom of the oven, always use an oven rack placed in at least the lowest position.

To use the Broil feature of the range, first consider what type of broiling you would like to perform. The closer you are to the broil burner, the faster you will evaporate moisture from the surface of food and the quicker the surface will brown. In a similar fashion, the further away you place the food (on the lowest rack, for example) the slower you will evaporate surface moisture and the longer it will take for the surface to brown. A good rule of thumb is to start about 6" away from the broiler and watch for how quickly the food is browning.

BROILER OPERATION

To light the broiler, push in and turn the thermostat and selector knobs to the position labeled BROIL on the control knob. In about twenty seconds, you will see a bright glow in the oven - this is the hot surface igniter. Once the igniter is hot enough for ignition, the gas valve will open, allowing the flow of gas into the broil burner. This may take up to one minute.

The broiler will have a blue flame that covers the Inconel® screen – after a few minutes, the screen will glow bright red/orange and radiate infrared energy. Remember the red surface is over 1800°F in temperature and can be a source of serious burns or injury.

The Bake burner and Broil burner will not operate at the same time; the convection fan will not operate during Broiling. The Broil function will not operate with door open.

GRILL OPERATION

To turn on the grill, make sure there is nothing on the grate. Push in and turn the control knob clockwise to the ON position. The power ON indicator light will glow indicating the grill valve is on. The grill is equipped with a flame-sensing ignition system – that automatically detects the presence of flame on the grill burner – and relights it in the event it should go out.

After cooking, allow the grill to cool completely. Once cooled remove the grate and discard grease and other food particles. The grill grate can be removed to expose the radiants - which may be lifted out and placed in the dishwasher for cleaning. The grate is porcelain coated and may be washed with hot soapy water and a soft brush.

BEST COOKING RESULTS WHEN USING YOUR GRILL

The intense radiant heat from the grill sears the surface of your food, locking in flavor.

- Add any barbecue sauces during the last few minutes of cooking, long enough to caramelize the sauce.
- For best results, turn food with tongs or a flat spatula to avoid piercing meat or poultry.
- Turn meat once when juices rise to the surface. Turning meat more than once results in the loss of meat juices.
- Never squeeze juices out of meat.
- Before cooking steaks or chops, trim most of the outside fat to prevent excessive flare-ups. Slash into the edges of steaks or chops to keep meat flat on the grill.
- Fish should be cooked at the lowest setting eight to ten minutes for every inch of thickness, measured at the thickest part of the fish.

GRILL CHART		
FOOD ITEM	INTERNAL TEMPERATURE	TIME
Hamburgers 1/2" to 3/4"	160°	8 to 10 minutes
Steaks 1" to 1-1/2"	Rare 140°	10 to 20 minutes
Steaks 1" to 1-1/2"	Medium 160°	12 to 25 minutes
Pork Chops 3/4" to 1"	145° & 3 minutes rest time	15 to 25 minutes
Lamb Chops	160°	12 to 15 minutes
Poultry Pieces	170°	25 to 35 minutes
Fish 1" Thick	145° Minimum	8 to 10 minutes

Allow grill to cool completely before cleaning. Remove the grates, grease collector and Stainless Steel Radiant and place in hot soapy water. Clean the grill with hot soapy water and a soft grill brush.

Do not apply water or cleaner directly on the infrared burner.

GRIDDLE OPERATION

The built-in griddle is made of polished steel to provide a smooth cooking surface. A griddle drip pan is included.

Always pre-heat the griddle on the low setting, at least ten minutes before cooking. The griddle burner is equipped with a hot surface igniter and gas safety valve system.

TO START COOKING:

- Push knob in and turn the knob clockwise to the MAX position. Preheat griddle for two to three minutes and turn knob to a medium or low cook setting.
- The blue indicator light comes on and stays on until the desired temperature setting is reached and then turns off and on with the heating cycle.
- For best results, add a small amount of butter, oil, or a cooking spray to the griddle surface. Fatty meats like bacon and sausage do not need extra fat.

SEASON THE GRIDDLE:

1. The griddle has a factory applied coating that must be washed off prior to use. (See Cleaning the Griddle)
2. Pour one tablespoon of vegetable oil (not corn or olive oil) and rub on the entire surface of the griddle using a rough towel.
3. Push the griddle control knob in and turn to a medium setting (350°F).
4. Heat until griddle begins to smoke. Turn off griddle and allow it to cool.
5. Returning to step 2, repeat the process three times.

When you are done "griddling" and while the griddle surface is still warm, remove any left-on food particles. Allow the griddle to cool and scrape off any excess grease from the surface with a flexible nylon spatula. Pull the spatula forward toward the front and push any material into the front grease receiver.

To clean the griddle, moisten a soft scrub cloth, adding a drop of mild hand dishwashing liquid to create a soapy lather - and wipe the griddle from left to right. Clean in rows from the top to the bottom, taking time to wash the entire griddle surface, including the sides. When you are done, rinse away all the soap from the cloth and wipe any suds from the griddle surface. Remove all remaining moisture from the griddle with the second, clean soft cloth. You may have to repeat this activity to ensure the griddle plate is dry and sparkling.

CLEANING THE GRIDDLE:

- The griddle is not to be removed for cleaning.
- Using a flat plastic spatula gently remove burned-on food.
- Clean the griddle thoroughly with hot soapy water and a rough towel.
- The griddle drip pan and trough should be cleaned after each use with hot soapy water and a sponge.
- It is normal for the griddle to darken with age and use, similar to commercial cooking equipment color.

GRIDDLE CHART		
FOOD ITEM	TEMP. SETTING	HEAT SETTING
Eggs	225°F to 250°F	Low
Bacon, Ham, Hot Dogs	300°F to 325°F	Medium - Low
Sausage, Grilled Cheese Sandwiches	325°F to 350°F	Medium
Pancakes, French Toast	350°F to 375°F	Medium
Hash Brown Potatoes, Grilled Onions	400°F to 425°F	Medium - High

The temperature settings are meant as a guide. You may need to vary the settings according to taste.

CARE AND CLEANING

It is always easier to clean as you go – and while some evenings you'd rather sit down with a good book instead of a Scrubbie, keeping your range cook top and oven in a ready to go state for the next meal makes everything a little more tolerable.

When cleaning the range:

- Use the mildest procedure that will do the job efficiently and effectively – and since some cleaners are harsher than others, it is best to try them on a small, inconspicuous area first.
- Use only clean, soft cloths, sponges, paper towels, plastic brushes, non-metal soap pads for cleaning and scouring.
- When cleaning the oven door, control panel, top curved section (called the bull nose) or the flat top area – always pretend it is made of wood – and rub the finish in the direction of the grain. This is the most effective cleaning direction, to prevent marring the surface.
- Any part of this appliance can be cleaned with hot, sudsy water. When rinsing is required, rinse thoroughly.
- Always wipe dry immediately to reduce the appearance of water marks.

TO CLEAN THE COOK TOP

The cook top is constructed from brushed Stainless Steel and burners feature polished aluminum heads. The burner caps are steel coated porcelain.

- Do not use abrasives on Stainless Steel. Use towels, sponges or soft plastic scrubbers. **RUB ONLY WITH THE "GRAIN"**.
- Do not use steel wool pads or green rough Scrubbie.
- Wash all cooking surfaces with hot water and dish detergent such as Simple Green.
- Rub stubborn spots with baking soda or liquid cleaner such as Windex All Surface Cleaner or 409.
- Grates and burner caps can be soaked in hot soapy water. Mild scouring cleaners can be used, such as Bon Ami or Cameo on grates and burner caps.

TO CLEAN THE OVEN

The oven interior is porcelainized and contains steel rack guides and racks. The infrared broiler does not need to be cleaned. Any soil is burned off by the intense heat.

- Place a medium glass baking dish filled with two cups of ammonia. Close the door and allow the dish to sit overnight. This process softens the soil for easier removal.
- Wash the interior of the oven with soap and water. Make a paste with baking soda and water and using a sponge or nylon pad rub away stubborn stains.
- Use mild scrubbing compounds such as Bon Ami or Cameo if necessary.
- Do not use steel wool pads or abrasive sponges or scrubbers.
- If necessary, spray oven cleaner can be used. **DO NOT SPRAY OVEN CLEANER INTO THE CONVECTION FANS OR UP ONTO THE INFRARED BROILER.**
- When spray oven cleaners are used, follow using a 1/4 cup vinegar mixed with one quart of water to rinse the oven.
- Do not use scouring powders on the glass window; oven spray may be used on the window. Rinse with vinegar & water solution.

CLEANING RECOMMENDATIONS

PART / MATERIAL	CLEANING SUGGESTIONS	BEING CAREFUL
Main Top/ Porcelain Enamel	Soft Scrub may be used here. With a cool or slightly warm surface, use a damp sponge or cloth as recommended by the manufacturer.	Since the surface is glass (it can be scratched by certain materials) try to rub gently in small circles to allow time and chemical reactions to take place.
Sealed Burners	Caps and burner heads can be removed for cleaning using hot sudsy water. A stiff nylon bristle toothbrush can be used to clean burner port openings.	Remember to dry out the ports (try to blow air through them if you like). Water clogged ports burn with erratic flames and could be dangerous.
Open Burners	The cast iron burner heads are heavy and porcelain coated. If they are dirty, remove any large debris and gently scrub under hot, soapy water.	Like the sealed burners, remember to dry out the ports (try to blow air through them if you like). Water clogged ports burn with erratic flames and could be dangerous.
Control Knobs/ Powder Paint	Use dry hands to pull off the knobs; hot sudsy water works best here...	...with a sponge to avoid scratching
Chrome Knob Bezels	Hot soapy water works well here, with a sponge or soft cloth.	As with any round feature that meets the stainless steel grain, be careful to clean the bezels in a circular motion – and not contact the S/Steel control panel.
Exterior Finish Island Trim	Use hot soapy water, Fantastic, Formula 409, rinse and dry immediately. For hard water spots, try household vinegar or CLR. If there is any heat discoloration, consider using Zud, Wright's All Purpose Polish or Blue Away.	Rub lightly in the direction of the grain of the Stainless Steel. Salt (sodium chloride), chlorine or chlorine compounds in some cleaners are corrosive to Stainless Steel.
Grates/Porcelain Enamel on Cast Iron	Hot water & detergent with scrubbie, or soap filled steel wool pad for really tough stains will work.	Remove sugar or acid based spills, they tend to attack the enamel. Remember the grates are heavy, use care when lifting and replacing.
Chrome Griddle	Moisten a soft scrub cloth, adding a drop of mild dishwashing liquid to create a soapy lather - and wipe the griddle from left to right.	Use plastic spatulas and spoons when working the griddle. See more tips in the discussion on griddle operation on page 25.

BAKING CHART				
FOOD	TRADITIONAL TEMPERATURE	TRADITIONAL TIME	INNOVECTION® CONVECTION TEMPERATURE	INNOVECTION® CONVECTION TIME
Bundt Cake	350°F	45 - 50 minutes	325°F	35 - 40 minutes
Cake, Layer Round 8" or 9"	350°F	30 - 35 minutes	325°F	25 - 30 minutes
Custard	350°F	35 - 40 minutes	Not recommended	--
Sheet Layer 9"x13"	350°F	40 - 50 minutes	325°F	30 - 35 minutes
Soufflé	350°F	45 - 50 minutes	325°F	35 - 45 minutes
Angel Food Cake	375°F	35 - 45 minutes	350°F	30 - 35 minutes
Baked Potato	375°F	60 - 75 minutes	350°F	50 - 55 minutes
Cookies/Choc Chip	375°F	10 - 12 minutes	350°F	8 - 10 minutes
Lasagna	375°F	55 - 60 minutes	350°F	45 - 50 minutes
Muffins	375°F	15 - 20 minutes	350°F	12 - 15 minutes
Quick Bread	375°F	30 - 35 minutes	350°F	20 - 25 minutes
Two Crusts Fruit Pie	375°F	55 - 60 minutes	350°F	50 - 55 minutes
Yeast Bread	375°F	30 - 35 minutes	350°F	25 - 30 minutes
Quiche	400°F	25 - 30 minutes	Not recommended	--
Pie Shell	425°F	10 - 12 minutes	400°F	7 - 9 minutes

ROASTING CHART				
FOOD	TRADITIONAL SETTING	INNOVECTION® CONVECTION SETTING	ROAST TIME MIN./LB.	INTERNAL TEMPERATURE
Beef Rib Roast	325°F	300°F	20 min. / lb. 25 min. / lb. 30 min. / lb.	Rare - 140°F Med. - 155°F Well - 170°F
Beef Tri-Tip	325°F	300°F	30 min. / lb.	Med. - 155°F
Leg Of Lamb	325°F	300°F	30 min. / lb.	Med. - 145°F
Pork Loin	325°F	300°F	35 min. / lb.	Med. - Well 170°F
Turkey - Unstuffed	325°F	300°F	9-12 min. / lb.	165°F breast 175°F thigh
Chicken - Whole	375°F	350°F	25 min. / lb.	170°F breast 175°F thigh
Stuffing				165°F

Whole, unstuffed poultry, such as chicken and turkey, should be placed on rack one or two with the legs and cavity opening pointing towards the back of the oven.

TO USE THE BROILER:

1. When using broil, the rack position depends on the food, and the thickness of the meat.
2. The oven door remains closed during broil. Opening the oven door turns the infrared element off.
3. When the door is closed the element will reignite.
4. Check your recipe or use our guide. Use a two-piece broil pan.
5. Most broiling uses rack positions three or four counting from the bottom.
6. Turn selector to Broil, push in oven knob and turn to the broil setting, the blue indicator light will come on.
7. For best results, broil small, flat cuts of meat such as steaks, hamburgers, chops or boneless chicken breasts.

BROILING CHART			
Food	Weight & Size	Rack	Time
Chicken Pieces	1 lb.	3	15 to 20 minutes
Hamburger	4 oz. and 1/2"	4	10 minutes
Pork Chops	1 lb. and 3/4"	3	14 minutes
Salmon Steak	1 lb.	4	8 to 10 minutes
Steak	12 oz. and 1"	3	Rare - 10 minutes Med. - 12 minutes Well - 15 minutes



TROUBLESHOOTING GUIDE

PROBLEM	POSSIBLE CAUSE	WHAT TO DO
Oven will not heat	<ul style="list-style-type: none"> No electrical power to the range Gas service is turned off Gas supply has been interrupted Look for red glow of hot surface igniter 	<ul style="list-style-type: none"> Check circuit breakers in house Try to light a surface burner Contact the gas company If no glow, call for service
Oven light does not work	<ul style="list-style-type: none"> Light switch is in the off position Light is burned out 	<ul style="list-style-type: none"> Try switching the light on Locate and test a new replacement light, unscrew glass lens, remove bad light, replace
Broiler will not light	<ul style="list-style-type: none"> No electrical power to the range Gas service is turned off Look for red glow of hot surface igniter 	<ul style="list-style-type: none"> Check circuit breakers in house Try to light a surface burner If no glow, call for service
Convection fan does not turn	<ul style="list-style-type: none"> Switch the fan on Unit in broil mode Bad fan 	<ul style="list-style-type: none"> Use the control panel switch Turn thermostat to bake temperatures Call for service
Igniters keep clicking	<ul style="list-style-type: none"> Reverse polarity of the electrical supply line Poor electrical ground 	<ul style="list-style-type: none"> Check the polarity with hand held tester Be sure range power cord has three prongs and plugs directly (no adapter) into the power receptacle
Condensation on the oven window	<ul style="list-style-type: none"> Cold appliance 	<ul style="list-style-type: none"> During cold weather, it is normal for some condensation to appear on the window, it will disappear in about ten minutes.
Foods over-cook	<ul style="list-style-type: none"> Incorrect temperature or cooking time Defective thermostat 	<ul style="list-style-type: none"> Reduce cooking time or temperature Watch that thermostat indicator light cycles on and off every five or ten minutes at temperature

WARRANTY REQUIREMENT

For reliable operation and for your own safety, this professional cooking equipment must be installed by a certified/licensed contractor.

Failure to comply will void any written or implied warranty.

Should the equipment require service during the standard warranty period, the receipt proving certified installation must be made available to American Range for verification.

If installation was not performed by a certified/licensed contractor be prepared to submit a major credit card for payment for proper installation prior to service.



13592 Desmond Street, Pacoima, CA 91331
818.897.0808 tel 888.753.9898 toll free
818.897.1670 fax
www.americanrange.com